

KAWAI

P R O D U C T S
C A T A L O G U E

2 0 1 1

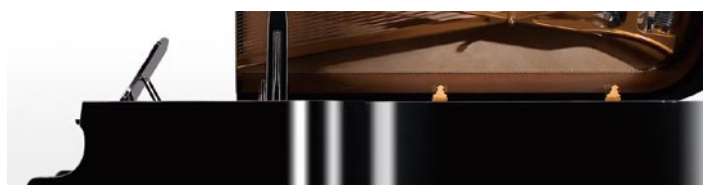

G R A N D P I A N O S



U P R I G H T P I A N O S



D I G I T A L P I A N O S

E N G L I S H / D E U T S C H

The Art of the Piano

A grand piano instrument consists of over nine-thousand precision parts, crafted from fine woods, rigid metals, soft fibres, compound resins, and countless other natural and man-made materials. Simply assembling each component into the mere form of a grand piano is, in itself, an immense undertaking.

Yet the process of crafting such raw materials into a precision instrument, that is capable of expressing the emotional subtleties of the human soul, an instrument that illuminates grand concert halls, leaving audiences enchanted, and an instrument that truly sings with a unique voice all of its own... such a process requires a passionate quest for excellence, with generations of knowledge and expertise.

At Kawai, this process is fittingly regarded as *the art of the piano*.



Die Kunst des Klavierbaus

Ein Flügel wird aus über 9000 Präzisionsteilen gefertigt. Dafür werden selbstverständlich nicht einfach irgendwelche Materialien verwendet. Kawai hat auch bei den kleinsten Teilen einen hohen Qualitätsanspruch. So werden ausschließlich feine Hölzer, besonders verwindungssteifes Metall, spezielle Harzmischungen, weiche Fasern und zahlreiche andere handgefertigte Materialien ausgewählt. Um beim Zusammenfügen der Teile die Form eines Flügels zu erreichen, bedarf es einer sehr exakten Arbeitsweise.

Dieser komplexe Prozess erfordert erstklassige handwerkliche Fähigkeiten, ein leidenschaftliches Streben nach Perfektion und ein immenses Wissen. Denn letztlich soll ein Flügel feinste Nuancen der Seele eines Pianisten zum Ausdruck bringen und mit seinem wahrhaftig einzigartigen Klang das Publikum in den Konzertsälen verzaubern.

Das genau ist es, was Kawai unter der „Kunst des Klavierbaus“ versteht.



GRAND PIANOS

RX Series

The RX Series is a unified line of six superb instruments, offering one consistent level of exceptional grand piano performance. Each RX Grand Piano is the result of uncompromising craftsmanship, honed by generations of experience and refinement.

Die RX Serie besteht aus einer Reihe von sechs herausragenden Instrumenten, die eine ausgewogene Qualität auf allen Ebenen des Flügelbaus repräsentieren. Jeder RX Flügel ist das Resultat großer handwerklicher Fertigkeiten, die über Generationen hinweg auf ihr heutiges Niveau verfeinert wurden.

Superb tone is the first hallmark of every Kawai piano, with countless hours of research and development paying dividends in perfecting the RX Series' exceptional sound. Yet, playing the piano is as much a tactile experience as it is auditory; professional pianists demand greater speed, control, and power from every key stroke. Fortunately, consistent, ultra-responsive touch remains a Kawai speciality, with continued innovation providing a truly unparalleled playing experience.

Der hervorragende Klang ist das erste Erkennungszeichen eines jeden „Kawai“ Klaviers. Durch unentwegte Forschung und Entwicklung konnte der Klang der RX Serie immer mehr perfektioniert werden. Das Spielen eines Klaviers ist jedoch nicht nur ein hörbares sondern auch ein fühlbares Erlebnis. Daher sind Tastatureigenschaften wie Geschwindigkeit, Anschlagkontrolle und Kraftaufwand für professionelle Pianisten von besonderer Bedeutung. Die Millennium III Tastatur erfüllt alle diese Eigenschaften und verleiht den Kawai Instrumenten ein einzigartiges Spielgefühl.

RX-7

227 (L) x 157 (W) x 102 (H) cm



RX-6

212 (L) x 154 (W) x 102 (H) cm



RX-5

197 (L) x 153 (W) x 102 (H) cm



RX-3 Conservatory

186 (L) x 152 (W) x 102 (H) cm



RX-3

186 (L) x 152 (W) x 102 (H) cm



RX-2

178 (L) x 152 (W) x 102 (H) cm

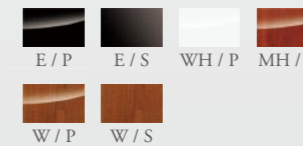

RX-1

164 (L) x 150 (W) x 102 (H) cm

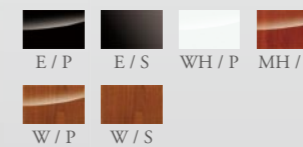

BABY GRAND PIANOS

GE & GM Series

The GE and GM models offer the meticulous attention to detail and quality of larger Kawai grand pianos, within a petite cabinet size - combining stylish elegance with outstanding performance, for an impressive addition to a family home or studio.

Die GE und GM Modelle erhalten dieselbe Aufmerksamkeit in puncto Detailarbeit und Qualität, wie die größeren Flügel von Kawai. Dank der kleineren Bauform, dem angenehmen Klang und dem klassischen Aussehen sind diese Modelle eine Bereicherung für das Spiel Zuhause oder den Einsatz in einem Studio.

GE-30

164 (L) x 150 (W) x 102 (H) cm



Sapele Mahogany Polish / Sapeli Mahagoni poliert

GE-20

154 (L) x 150 (W) x 102 (H) cm



GM-10

150 (L) x 150 (W) x 102 (H) cm



GE-30, GE-20, and GM-10 ATX models also available, depending on market area. / Die Modelle GE-30, GE-20 und GM-10 ATX sind nicht in jedem Land erhältlich.

SPECIFICATIONS

		RX-7	RX-6	RX-5	RX-3	RX-2	RX-1	GE-30	GE-20	GM-10
Size	Height	102 cm	102 cm	102 cm	102 cm *	102 cm	102 cm	102 cm	102 cm	102 cm
	Width	157 cm	154 cm	153 cm	152 cm	152 cm	150 cm	150 cm	150 cm	150 cm
	Length	227 cm	212 cm	197 cm	186 cm	178 cm	164 cm	164 cm	154 cm	150 cm
	Weight	391 kg	373 kg	342 kg	325 kg	315 kg	308 kg	302 kg	290 kg	272 kg
Soundboard	Material	Solid Spruce	Solid Spruce	Solid Spruce	Solid Spruce	Solid Spruce	Solid Spruce	Solid Spruce	Solid Spruce	Solid Spruce
	Area	1.70 m ²	1.60 m ²	1.41 m ²	1.33 m ²	1.23 m ²	1.17 m ²	1.17m ²	1.03 m ²	0.98 m ²
No. of Beams		4	4	4	4	3	3	3	3	2
Action		Millennium III	Millennium III	Millennium III	Millennium III	Millennium III	Millennium III	Millennium III	Millennium III	Ultra Responsive
Hammers	Material	Mahogany	Mahogany	Mahogany	Mahogany	Mahogany	Mahogany	Maple	Maple	Maple
	Felting	All Underfelted	All Underfelted	All Underfelted	All Underfelted	All Underfelted	All Underfelted	All Underfelted	All Underfelted	All Underfelted
Key Surfaces		NEOTEX	NEOTEX	NEOTEX	NEOTEX	NEOTEX	NEOTEX	NEOTEX	NEOTEX	Acrylic / Phenol
Duplex Scale		Yes	Yes	Yes	Yes	Yes	Yes	Yes	Yes	-
Agraffes		1" - 54 th key	1" - 54 th key	1" - 54 th key	1" - 54 th key	1" - 54 th key	1" - 46 th key	1" - 46 th key	1" - 46 th key	-
'Soft Fall' Fallboard		Yes	Yes	Yes	Yes	Yes	Yes	Yes	Yes	-
Caster Configuration		Double, Brass	Double, Brass	Single, Brass	Single, Brass	Single, Brass	Single, Brass	Single, Brass	Single, Brass	Single, Brass
Lock		Yes	Yes	Yes	Yes	Yes	Yes	-	-	-

* RX-3 Conservatory height = 103 cm

CRYSTAL GRAND PIANOS

CR Series

With their truly stunning transparent acrylic body, the CR-40A and CR-30 Crystal Grand pianos are guaranteed to captivate performers and audience members alike.

Das extravagante Erscheinungsbild der Flügelmodelle CR-40A und CR-30 im transparenten Plexiglasgehäuse garantiert die Faszination von Pianisten und Publikum gleichermaßen.

		CR-40A	CR-30
Size	Height	100 cm	99 cm
	Width	150 cm	150 cm
	Length	185 cm	178 cm
	Weight	425 kg	395 kg
Action		Ultra Responsive	



ACOUSTIC PIANO FINISHES



E / P

Ebony Polish
Schwarz poliert



E / S

Ebony Satin
Schwarz satiniert



WH / P

Snow White Polish
Weiß poliert



SM / P

Sapele Mahogany Polish
Sapeli Mahagoni poliert



MH / P

Mahogany Polish
Mahagoni poliert



MH / S

Mahogany Satin
Mahagoni satiniert

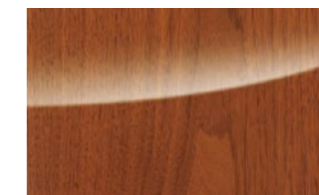

W / P

Walnut Polish
Nussbaum poliert

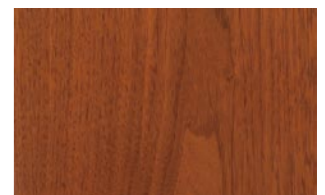

W / S

Walnut Satin
Nussbaum satiniert

Availability of cabinet finishes may vary depending on market area. / Nicht in allen Verkaufsgebieten lieferbar.

UPRIGHT PIANOS

K Series

K Series upright pianos offer a level of tonal quality and performance to rival many grand pianos. With sturdy construction for years of reliable service, these instruments are an excellent choice for auditoriums, schools, and other institutional settings.

Die Klaviere der K-Serie bieten eine Klangfülle und Tonqualität, die den Vergleich mit so manchem Flügel nicht scheuen muss. Mit ihrer robusten Konstruktion sind die Modelle ideal für den Einsatz in kleinen Konzerträumen, Schulen und anderen institutionellen Einrichtungen.

In 1971 Kawai revolutionised piano technology by introducing ABS parts within the fine workings of the piano action. This rigid, atmospherically stable compound material, addressed many of the problems associated with wooden components, such as breakages under continual high stress, and shrinking and swelling due to changes in climate. The Millennium III Upright Action utilises stronger ABS Carbon parts, allowing Kawai scientists to further optimise key repetition and response speed.

Kawai revolutionierte 1971 den Klavierbau durch die Verwendung des Werkstoffes ABS in der Klaviermechanik. Die Vorteile dieses stabilen, leichtgängigen und haltbaren Materials gegenüber Holz liegen auf der Hand: Kein Durchbrechen bei kontinuierlich stärkeren Belastungen und kein Zusammenziehen bzw. Ausdehnen bei klimatischen Änderungen. Die Millennium III Tastaturen verwenden bereits Teile aus dem noch stabileren Werkstoff ABS Karbon. So wurden Repetierfähigkeit und Anschlagkontrolle nochmal deutlich verbessert.

K-8

132 (H) x 153 (W) x 65 (D) cm



K-3

122 (H) x 151 (W) x 59 (D) cm



Mahogany Polish / Mahagoni poliert



K-6

132 (H) x 154 (W) x 65 (D) cm



K-2

114 (H) x 148 (W) x 57 (D) cm

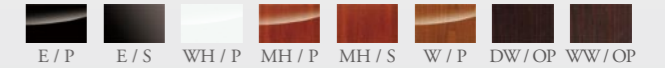

Dark Walnut Open Pore / Nussbaum dunkel offenporig

K-5

125 (H) x 151 (W) x 59 (D) cm



K-15

110 (H) x 149 (W) x 59 (D) cm

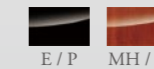

HYBRID PIANOS

AnyTimeX

AnyTimeX instruments incorporate an acoustic muting feature with powerful digital audio components, allowing pianists to continue enjoying the distinctive feeling of a traditional piano more discreetly, without disturbing family members or neighbours.

Die AnyTimeX Modelle sind mit einer Stummschaltung für den akustischen Teil des Klaviers und einer hochwertigen Digitalpiano Technik ausgestattet. Dank dieser Kombination kann der Pianist das Spiegegefühl eines traditionellen Klaviers genießen und dabei die digitale Klangerzeugung über Kopfhörer hören, ohne andere zu stören.

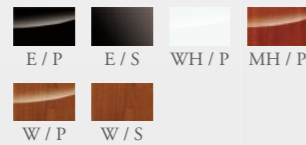

RX-2 ATX

178 (L) x 152 (W) x 102 (H) cm



K-5 ATX

125 (H) x 151 (W) x 59 (D) cm



SPECIFICATIONS

		K-8	K-6	K-5	K-3	K-2	K-15
Size	Height	132 cm	132 cm	125 cm	122 cm	114 cm	110 cm
	Width	153 cm	154 cm	151 cm	151 cm	148 cm	149 cm
	Depth	65 cm	65 cm	59 cm	59 cm	57 cm	59 cm
	Weight	260 kg	254 kg	223 kg	220 kg	200 kg	193 kg
Soundboard	Material	Solid Spruce	Solid Spruce	Solid Spruce	Solid Spruce	Solid Spruce	Solid Spruce
	Area	1.53 m ²	1.53 m ²	1.39 m ²	1.39 m ²	1.32 m ²	1.31 m ²
Back Posts		6	6	5	4	4	4
Action		Millennium III	Millennium III	Millennium III	Millennium III	Millennium III	Ultra Responsive
Hammers	Material	Mahogany	Mahogany	Mahogany	Maple / Sycamore	Maple / Sycamore	Maple / Sycamore
	Felting	All Underfelted	All Underfelted	All Underfelted	Single felted	Single felted	Single felted
Key Surfaces		NEOTEX	NEOTEX	NEOTEX	Acrylic / Phenol	Acrylic / Phenol	Acrylic / Phenol
Tuning Pins		Nickel	Nickel	Nickel	Nickel	Nickel	Nickel
Duplex Scale		Fore / Back	Fore / Back	Fore	-	-	-
Agraffes		1" - 51" key	1" - 51" key	-	-	-	-
Upper Panel Tone Release		Full Spectrum Tone Release	Inverse Tone System	Inverse Tone System	-	-	-
Front Caster Configuration		Double, Brass	Double, Brass	Double, Brass	Double, Brass	Single, Brass	-
Lock		Yes	Yes	Yes	-	-	-

K-8 & K-6 sostenuto pedal models also available, depending on market area. / Die Modelle K8 & K6 sind in einigen Ländern auch mit Sostenuto Pedal erhältlich.

	RX-2 / GE-30 / GE-20 / GM-10*	K-5 ATX*	K-3 ATX	K-2 ATX	K-15 ATX
Sound Source	Ultra Progressive Harmonic Imaging™				
Polyphony	max. 192 notes		Harmonic Imaging™		
Internal Sounds	22 voices		max. 192 notes		
Display	16 x 2 characters LCD		22 voices		
Reverb	5 types		16 x 2 characters LCD		
Metronome	10 time signatures		5 types		
Recorder	9 songs, 75,000 notes		10 time signatures		
Virtual Technician	Voicing, Damper Resonance, String Resonance, Key Off Effect, Touch Curve, Temperament, Stretch Tuning		9 songs, 75,000 notes		
Other Features	Dual, Dual Balance, Transpose, Tuning, Loudness, User Memory, Factory Reset		Voicing, Damper Resonance, String Resonance, Key Off Effect, Touch Curve, Temperament, Stretch Tuning		
Jacks	MIDI (IN, OUT), USB (to Host), LINE OUT (L, R), LINE IN (L, R), Headphones x 2		Dual, Dual Balance, Transpose, Tuning, Loudness, User Memory, Factory Reset		
			MIDI (IN, OUT), USB (to Host), LINE OUT (L, R), LINE IN (L, R), Headphones x 2		
			Transpose, Tuning		
			MIDI (IN, OUT), LINE OUT (L, R), Headphones x 2		

*ATX model with soundboard speaker also available. / Die Modelle K-5 ATX und RX-2 ATX sind auch mit Soundboard Lautsprecher System (als ATX-f Ausführung) erhältlich. Headphones included with all AnyTime instruments. / Alle AnyTime Modelle beinhalten einen Kopfhörer im Lieferumfang.

ANYTIME X : FEATURE HIGHLIGHTS

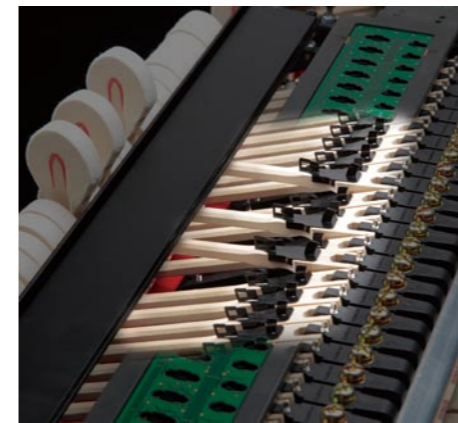

All AnyTimeX instruments utilise sensors integrated within the fine workings of the piano action to detect the precise movements of each hammer.

Alle AnyTimeX Modelle verwenden Sensoren in der Klaviermechanik, um die Bewegungen eines jeden Hammers präzise erkennen zu können.



The slide-out control panel discretely placed below the keybed, provides convenient access to digital features without devaluing the piano's traditional appearance.

Das ausfahrbare Bedienfeld ist unauffällig unter dem Spieltisch angebracht. Durch einen leichten Druck fährt es heraus und bringt ein Display und verschiedene Funktionstasten zum Vorschein.



The latest ATX-f instruments allow digital features to be used without headphones, channelling sound energy back onto the piano's wooden soundboard.

Dank der Verwendung eines Resonanzboden Lautsprecher Systems (Soundboard Speaker System), können Sie den digitalen Klang der neuesten ATX-f Instrumente auch ohne Kopfhörer genießen.

DIGITAL PIANOS

CA Series

The Concert Artist range are quite simply the finest digital pianos available, with our rich, 80 year heritage in crafting fine acoustic instruments inspiring a selection of digital pianos that deliver nuance, artistry, and an exceptional musical experience.

Die mehr als 80-jährige Klavierbautradition spiegelt sich nicht nur im Bau erstklassiger akustischer Klaviere wieder, sondern gibt den Kawai Ingenieuren eine ideale Basis für die Entwicklung von hochwertigen Digitalpianos, was sich in den Modellen der Concert Artist Serie widerspiegelt.

CA93

- RM3 Grand
- Ivory Touch
- LET-OFF
- UPHI
- MAX POLY 192
- 80 SOUNDS
- LCD DISPLAY
- LESSON
- USB TO HOST
- USB TO DEVICE
- MP3/WAV
- SOUND BOARD
- HYBRID

Soundboard Speaker

CA63

- RM3 Grand
- Ivory Touch
- UPHI
- MAX POLY 192
- 60 SOUNDS
- LCD DISPLAY
- LESSON
- USB TO HOST
- USB TO DEVICE
- MP3/WAV

CA13

- RM3 Grand
- Ivory Touch
- PHI
- MAX POLY 96
- 8 SOUNDS

DIGITAL PIANOS

CN Series

An affordable range of high specification instruments, the popular CN Series feature Progressive Harmonic Imaging™ 88-key sampling technology and grade-weighted keyboard actions, establishing a new standard in digital piano value and performance.

Die Modelle der CN Serie bieten eine umfangreiche Ausstattung zu einem attraktiven Preis. Die Kawai Klangerzeugung Progressive Harmonic Imaging™ mit 88 Tasten Sampling und die Tastatur mit Hammermechanik bieten dem Pianisten ein erstklassiges Klangerlebnis und ein authentisches Spielgefühl.

CN43

- RHAction
- Ivory Touch
- LET-OFF
- PHI
- MAX POLY 192
- 323 SOUNDS (+12DRUM)
- LCD DISPLAY
- LESSON
- USB TO HOST
- USB TO DEVICE
- MP3/WAV
- Bluetooth

CN33

- RHAction
- Ivory Touch
- LET-OFF
- PHI
- MAX POLY 96
- 36 SOUNDS
- LCD DISPLAY
- LESSON
- USB TO HOST
- USB TO DEVICE

CN23

- RHAction
- Ivory Touch
- PHI
- MAX POLY 96
- 15 SOUNDS
- LESSON

RM3 Grand

The RM3 Grand keyboard action utilised by the Concert Artist series combines the three core principles of realistic **mechanism, motion, and materials** to recreate the exceptional touch of the finest concert grand pianos.

Die Concert Artist Modelle sind mit der RM3 Grand Holztastatur ausgestattet. Mit ihrer für Digitalpianos einzigartigen Tastenlänge und der Mechanikumsatzung mit Waagebalken, vermittelt sie dem Pianisten ein exzellentes Spielgefühl.

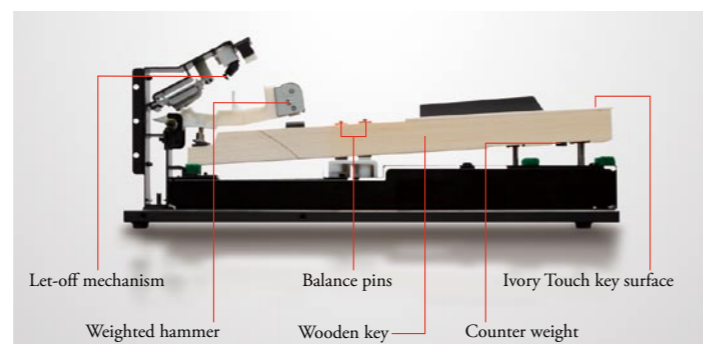

Responsive Hammer Action

The Responsive Hammer (RH) keyboard action utilised by the CN series instruments features grade-weighted hammers, realistic key movement, and a sturdy, rigid design that ensures a smooth and natural piano playing experience.

Die Modelle der CN Serie sind mit der Responsive Hammer (RH) Tastaturmechanik ausgestattet. Sie überzeugt durch unterschiedliche Gewichtungszonen, realistische Tastenbewegungen und eine stabile und verwindungssteife Mechanik.

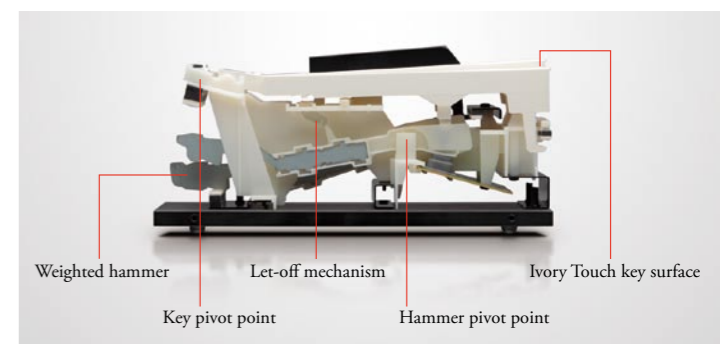

LUXURY DIGITAL PIANOS

Classic Series

The new Classic Series range of premium digital pianos combine Kawai's superior keyboard action and sound technology with finely crafted polished ebony cabinets, resulting in a collection of stunning instruments that play as beautifully as they look.

Die neue Classic Serie kombiniert eine erstklassige Tastaturmechanik und Klangtechnologie mit einem luxuriösen Design in Akustikpiano Optik mit einer schwarzen Hochglanzlackierung. Das Ergebnis ist eine beeindruckende Serie, die sowohl optisch als auch klanglich zu überzeugen weiß.



CS9

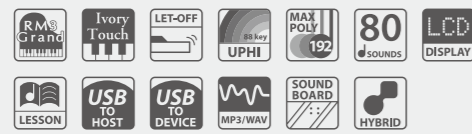

Soundboard Speaker



CS6



CS3



SPECIFICATIONS

	CA93	CA63	CA13
Keyboard	88 wooden keys with Ivory Touch key surfaces		
Action	RM3 Grand with Let-off	RM3 Grand	
Sound Source	Ultra Progressive Harmonic Imaging™ (UPHI), 88-key piano sampling		Progressive Harmonic Imaging™ (PHI), 88-key piano sampling
Internal Sounds	80 voices	60 voices	8 voices
Polyphony	max. 192 notes		max. 96 notes
Display	16 x 2 characters LCD		-
Reverb	Room 1, Room 2, Stage, Hall 1, Hall 2		Room, Stage, Hall
Effects	Chorus, Delay 1, Delay 2, Delay 3, Tremolo, Rotary 1, Rotary 2		Preset
Recorder	10 song, 2 track recorder - 90,000 notes		3 song, 1 track recorder - 15,000 notes
USB Functions	Play MP3/WAV/MID, Record MP3/WAV, Convert Song to Audio, Load/Save Recorder song		
Demo Songs	36 songs + 42/29 Piano Music pieces *	34 songs + 42/29 Piano Music pieces *	8 songs + 42/29 Piano Music pieces *
Concert Magic	176 songs		
Lesson Function	Finger exercises + Alfred or Burgmüller, Czerny, Beyer, and Bach lesson books *		Alfred or Burgmüller and Czerny lesson books *
Virtual Technician	Voicing, Damper Resonance, String Resonance, Key Off Effect, User Touch Curve, Temperament, Stretch Tuning		
Other Features	Dual, Split, Dual/Split Balance Adjust, Four Hands Mode, Key/Song Transpose, Tuning, Metronome (with 100 rhythms), Registrations, Preset/User EQ, Speaker/Headphone Volume		Damper Resonance, Touch Curve, Four Hands Mode, Transpose, Tuning, Metronome, Brilliance, MIDI functions
Jacks	MIDI (IN/OUT/THRU), USB (to Host, to Device), LINE IN (L/MONO, R), LINE IN Level Adjust, STEREO IN, LINE OUT (L/MONO, R), Headphones x 2		MIDI (IN/OUT), Headphones x 2
Pedals	Damper (with Half-Pedal support), Sostenuto, Soft		
Speakers	7 cm x 4 + 1.9 cm x 2 132 cm x 53 cm Soundboard Speaker System	13 cm x 2 + 5 cm x 2	12 cm x 2 + 5 cm x 2
Output Power	50 W x 2 + 35 W transducer	50 W x 2	15 W x 2
Dimensions	146 (W) x 47 (D) x 92 (H) cm	144 (W) x 47 (D) x 91 (H) cm	137 (W) x 46 (D) x 88 (H) cm
Weight	87.0 kg	76.0 kg	59.0 kg

	CN43	CN33	CN23
Keyboard	88 weighted keys with Ivory Touch key surfaces		
Action	Responsive Hammer action with Let-off		Responsive Hammer action
Sound Source	Progressive Harmonic Imaging™ (PHI), 88-key piano sampling		
Internal Sounds	323 voices + 12 drum kits (GM2 compatible)	36 voices	15 voices
Polyphony	max. 192 notes	max. 96 notes	
Display	16 x 2 characters LCD	3 digit LED	-
Reverb	Room 1, Room 2, Stage, Hall 1, Hall 2, Plate	Room 1, Room 2, Stage, Hall 1, Hall 2	Room, Stage, Hall
Effects	12 types	7 types	Preset
Recorder	3 song, 2 track recorder - 90,000 notes	3 song, 2 track recorder - 15,000 notes	3 song, 1 track recorder - 15,000 notes
USB Functions	Play/Record MP3/WAV/MID, Convert to Audio, Load/Save	Load/Save Recorder song	-
Rhythm Section	100 rhythms x 2 variations, Selectable parts, Preset chord prog.	-	-
Demo Songs	34 songs	30 songs	15 songs
Concert Magic	88 songs		
Lesson Function	Alfred or Burgmüller and Czerny lesson books *		
Other Features	Damper Effect, String Resonance, Touch Curve, Temperament, Dual, Split, Balance Slider, Four Hands Mode, Transpose, Tuning, Metronome, Panel Lock		Damper Effect, Touch Curve, Dual, Transpose, Tuning, Metronome
Jacks	MIDI (IN/OUT), USB (to Host, to Device), LINE IN (L/MONO, R), LINE OUT (L/MONO, R), Headphones x 2		
Pedals	Damper (with Half-Pedal support), Sostenuto, Soft		
Speakers	16 cm x 2 + 5 cm x 2	16 cm x 2	12 cm x 2
Output Power	50 W x 2	20 W x 2	
Dimensions	138 (W) x 47 (D) x 88 (H) cm		137 (W) x 41 (D) x 84 (H) cm
Weight	57.5 kg	54.0 kg	42.0 kg

	CS9	CS6	CS3
Keyboard	88 wooden keys with Ivory Touch key surfaces		88 weighted keys with Ivory Touch key surfaces
Action	RM3 Grand with Let-off		Responsive Hammer action with Let-off
Sound Source	Ultra Progressive Harmonic Imaging™ (UPHI), 88-key piano sampling		Progressive Harmonic Imaging™ (PHI), 88-key piano sampling
Internal Sounds	80 voices	60 voices	15 voices
Polyphony	max. 192 notes		max. 96 notes
Display	16 x 2 characters LCD		-
Reverb	Room 1, Room 2, Stage, Hall 1, Hall 2		Room, Stage, Hall
Effects	Chorus, Delay 1, Delay 2, Delay 3, Tremolo, Rotary 1, Rotary 2		Preset
Recorder	10 song, 2 track recorder - 90,000 notes		3 song, 1 track recorder - 15,000 notes
USB Functions	Play MP3/WAV/MID, Record MP3/WAV, Convert Song to Audio, Load/Save Recorder song		
Demo Songs	36 songs + 42/29 Piano Music pieces *	34 songs + 42/29 Piano Music pieces *	15 songs + 42/29 Piano Music pieces *
Concert Magic	176 songs		
Lesson Function	Finger exercises + Alfred or Burgmüller, Czerny, Beyer, and Bach lesson books *		Alfred or Burgmüller and Czerny lesson books *
Virtual Technician	Voicing, Damper Resonance, String Resonance, Key Off Effect, User Touch Curve, Temperament, Stretch Tuning		
Other Features	Dual, Split, Dual/Split Balance Adjust, Four Hands Mode, Key/Song Transpose, Tuning, Metronome (with 100 rhythms), Registrations, Preset/User EQ, Speaker/Headphone Volume, Auto Power Off		Damper Resonance, Touch Curve, Four Hands Mode, Transpose, Tuning, Metronome, Brilliance, MIDI functions
Jacks	MIDI (IN/OUT/THRU), USB (to Host, to Device), LINE IN (L/MONO, R), LINE IN Level Adjust, STEREO IN, LINE OUT (L/MONO, R), Headphones x 2		
Pedals	Damper (with Half-Pedal support), Sostenuto, Soft		
Speakers	7 cm x 4 + 1.9 cm x 2 132 cm x 53 cm Soundboard Speaker System	13 cm x 2 + 5 cm x 2	12 cm x 2 + 5 cm x 2
Output Power	50 W x 2 + 35 W transducer	50 W x 2	20 W x 2
Dimensions	151 (W) x 54 (D) x 105 (H) cm	145 (W) x 47 (D) x 95 (H) cm	142 (W) x 43 (D) x 91 (H) cm
Weight	102.0 kg	80.0 kg	55.0 kg

* depending on market area

COMPACT DIGITAL PIANOS

CL Series

The Compact Line range of digital pianos provide an excellent introduction to Kawai quality, and are ideally suited to pianists that require a modern, slimline instrument without wishing to sacrifice touch authenticity or tonal quality.

Die Modelle der Compact Line Serie eignen sich ideal für Pianisten, die ein Instrument mit einer kompakten Bauweise benötigen, ohne auf eine authentische Tastatur und Klangqualität verzichten zu müssen.



CL36

CL26

PORTABLE DIGITAL PIANO

ES6

Compact and portable, the multi-purpose ES6 features a powerful speaker system, professionally arranged accompaniments, and a selection of excellent sounds, providing a range of musical opportunities – wherever the venue, and whatever the occasion.

Kompakt und portabel – dieses Digitalpiano für alle Einsatzzwecke bietet eine authentisch gewichtete Tastatur, ein beeindruckendes Lautsprechersystem und eine umfassende Auswahl an Klängen für jede Gelegenheit.



Additional HM-3U Designer Stand & F-300H Triple Pedal accessories also available.
Der HM-3U Design Ständer und das F-300H Dreifach Pedal sind als optionales Zubehör erhältlich.

SPECIFICATIONS

	CL36	CL26
Keyboard	88 weighted keys with Ivory Touch key surfaces	88 weighted keys
Action	Responsive Hammer action	Advanced Hammer Action IV-F
Sound Source	Progressive Harmonic Imaging™ (PHI), 88-key piano sampling	Harmonic Imaging™, 88-key piano sampling
Internal Sounds	15 voices	8 voices
Polyphony	max. 96 notes	-
Recorder	3 song, 1 track recorder - 15,000 notes	-
Demo Songs	15 songs	8 songs
Concert Magic	40 songs	-
Lesson Function	Alfred or Burgmüller and Czerny lesson books, depending on market area	-
Other Features	Damper Effect, Touch Curve, Dual, Reverb Four Hands Mode, Transpose, Tuning, Metronome, Auto Power Off	Touch Curve, Dual, Reverb Transpose, Tuning, Metronome, Auto Power Off
Jacks	MIDI (IN/OUT), Headphones x 2, Pedal	MIDI (IN/OUT), Headphones x 2, Pedal
Pedals	Damper (with Half-Pedal support), Sostenuto, Soft	Damper (with Half-Pedal support) (F-10H unit)
Speakers	(12 x 8 cm) x 2	-
Output Power	15 W x 2	15 W x 2
Dimensions	137 (W) x 29.5 (D) x 77 (H) cm	128 (W) x 27 (D) x 77 (H) cm
Weight	36.5 kg	28.5 kg

SPECIFICATIONS

Keyboard	88 weighted keys
Action	Advanced Hammer Action IV-F
Sound Source	Harmonic Imaging™, 88-key piano sampling
Internal Sounds	32 voices
Polyphony	max. 192 notes
Display	3 digit LED
Reverb & Effects	Room 1, 2, Stage, Hall 1, 2 / Chorus, Delay 1, 2, 3, Tremolo, Rotary 1, 2
Recorder	4 song, 2 track recorder - 60,000 notes
Accompaniment	Rhythm Section: 100 styles (x 2 variations), One Finger Ad-Lib™
Other Features	Damper Effect, String Resonance, Touch Curve, Dual, Split, Balance Adjust, Four Hands Mode, Transpose, Tuning, Metronome
Jacks	MIDI (IN/OUT), USB (to Host), LINE IN (STEREO), LINE OUT (L / MONO, R), Headphones x 2, Pedal
Pedals	Damper (with Half-Pedal support), Sostenuto and Soft with optional F-300H
Speakers	5 cm x 4 + (8 x 12 cm) x 2 (Bass-reflex speaker enclosure)
Output Power	13 W x 2
Dimensions	136 (W) x 34.5 (D) x 14 (H) cm
Weight	21.5 kg



Improved 6-speaker sound system delivers deep bass and crisp treble frequencies.
Das Lautsprechersystem des ES6 mit 6 Lautsprechern liefert einen kräftigen Bass und klare Höhen.

DIGITAL STAGE PIANOS

MP Series

Regarded by music industry insiders as quintessential stage pianos, the MP Series offer unrivalled touch, superb sound, and excellent live performance control – fulfilling the requirements of professional musicians, whether in the studio or on tour.

Für Insider zählen die Modelle MP10 und MP6 zu den besten Stage Pianos. Das unvergleichliche Spielgefühl, der hervorragende Klang und die exzellenten Live-Funktionen erfüllen höchste Ansprüche von professionellen Musikern im Studio und auf der Bühne.



MP 10



MP6



SPECIFICATIONS

	MP10	MP6
Keyboard	88 wooden keys with Ivory Touch key surfaces	88 weighted keys with Ivory Touch key surfaces
Action	RM3 Grand with Let-off	Responsive Hammer action with Let-off
Sound Source	Ultra Progressive Harmonic Imaging™ (UPHI), 88-key piano sampling	Progressive Harmonic Imaging™ (PHI), 88-key piano sampling
Sections / Zones	Sections: PIANO, E.PIANO, SUB, MIDI	Zones: 4 x internal, 4 x external (MIDI)
Internal Sounds	27 voices (9 x PIANO, 9 x E.PIANO, 9 x SUB)	256 voices (8 categories x 8 sounds x 4 variations) + Tonewheel Simulator
Polyphony	max. 192 notes	
Display	128 x 64 pixel LCD	16 x 2 characters LCD
Effects	7 Reverb types, 25 Effects types, 6 Amp Simulator types (E.PIANO section only)	7 Reverb types, 23 Effects types, 1 Amp Simulator type (zone 1 only)
USB Functions	Play MP3/WAV/MID, Record MP3/WAV/MID, Overdub, Convert Song to Audio Load/Save: One Sound, One Setup, SMF, All Sound, All Setup, All Backup	Play MP3/WAV/MID, Record MP3/WAV/MID Load/Save: Setup, Sound, SMF, System Backup
Controls	Pitch Bend, Modulation, Master Volume, Line In Volume, Section Volume (x 4), 3-band EQ, Reverb Depth (x 3), Amp Drive, Assignable Knobs (x 4), MMC Transport	Pitch Bend, Modulation, Master Volume, Zone Volume (x 4), Assignable Knobs (x 4), MMC Transport
Virtual Technician	Voicing, Damper Resonance, String Resonance, Key Off Effect, User Touch Curve, Temperament, Stretch Tuning, ADSR Tone Modify Stereo Width, Damper Noise, Hammer Delay, Fall Back Noise, Brilliance	
Other Features	Transpose, Tuning, Metronome (with 100 rhythms), SETUPS, 10 song recorder	
Jacks	MIDI (IN/OUT/THRU), USB (to Host, to Device), LINE IN (L/MONO, R), LINE OUT (L/MONO, R), XLR OUT (L, R) with Ground Lift switch, Headphones x 1, Damper / Soft Pedal, Expression Pedal, Foot Switch	MIDI (IN/OUT/THRU), USB (to Host, to Device), LINE OUT (L/MONO, R), Headphones x 1, Damper Pedal, Expression Pedal, Foot Switch
Pedals	Damper (with Half-Pedal support), Soft (F-20 unit)	Damper (with Half-Pedal support) (F-10H unit)
Dimensions	138 (W) x 43 (D) x 18.5 (H) cm	136 (W) x 35 (D) x 18 (H) cm
Weight	32.0 kg	21.5 kg

DIGITAL PIANO FEATURES



Kawai's premium digital piano instruments feature unique, wooden key actions, with central balance points allowing the weight and movement of each key to accurately represent that of a concert grand piano.

Kawai's Premium Digitalpiano Modelle sind mit der einzigartigen Kawai Holztastatur und einer Waagebalken Mechanik in der Mitte der Tasten ausgestattet, was dem Pianisten ein sehr authentisches Spielgefühl ermöglicht.



Kawai's mid-range digital piano instruments utilise plastic key, graded hammer actions, with a springless design ensuring consistent upward and downward motion, and a naturally smooth piano playing experience.



Die Mittelklasse Digitalpianos von Kawai sind mit einer aufwendig entwickelten Kunststoffastatur mit Hammermechanik ausgestattet. Die federlose Konstruktion adaptiert das Spielgefühl durch bewegliche Hämmer auf natürliche Weise.



Instruments equipped with Ivory Touch, feature finely textured ivory-like key surfaces that absorb moisture and assist control, while let-off recreates the subtle 'notch' sensation felt when gently playing the keys of a grand.



Instrumente, die mit Ivory Touch ausgestattet sind, zeichnen sich durch einen Elfenbein-ähnlichen Tastenbelag aus, der Feuchtigkeit absorbiert. Die Let-Off Mechanik ist eine integrierte Druckpunkt Simulation, die das Spielgefühl noch authentischer macht.



Kawai's latest digital instruments feature MP3/WAV record and playback functionality, allowing musicians to accompany with their favourite artists, or create digital recordings of performances without leaving the keyboard.

Einige Kawai Modelle sind mit einer Funktion zur Aufzeichnung und Wiedergabe von Audio Dateien (MP3/WAV) ausgestattet. Lassen Sie sich von Ihrem Lieblingskünstler begleiten oder nehmen Sie einfach Ihr Spiel als Audio Datei auf.



Mid-range digital pianos present useful information such as the currently selected sound or setting using an LED display, while premium models feature an LCD display, providing greater detail.



Die Mittelklasse Modelle zeigen aktuelle Einstellungen in einem LED Display an. Die Premium Modelle sind mit einem LCD Display ausgestattet und zeigen die aktuellen Einstellungen komfortabel an.



The revolutionary Soundboard Speaker System, utilised by the CS9 and CA93 models embraces the rich, harmonic qualities of wood, channelling sound energy onto a spruce soundboard to deliver a warm, ambient tone.

Die Modelle CS9 und CA93 sind mit dem revolutionären Soundboard Speaker System ausgestattet. In einer speziellen Form wird das Tonsignal auf einen Resonanzboden aus Fichte übertragen und versetzt ihn in Schwingung, wodurch ein unglaublich kraftvolles und räumliches Klangbild entsteht.



Harmonic Imaging is the technology used to recreate the rich sound of a grand piano, and ensures that all Kawai digital instruments offer a smooth tonal transition from pianissimo to fortissimo. A hand-built EX Concert Grand is at the heart of every Kawai digital piano, with 88-key piano sampling capturing the unique harmonic character of each individual note, and enhanced forms of Progressive and now Ultra Progressive Harmonic Imaging delivering the most expressive grand piano sound ever realised.



Harmonic Imaging heißt die Technologie, mit der Kawai den besonderen Klang des handgearbeiteten und weltbekannten Kawai Konzertflügels reproduziert. Alle 88 Tasten dieses außergewöhnlichen Instrumentes – jede mit ihrem eigenen individuellen Charakter – wurden aufgezeichnet und analysiert. Die neuen erweiterten Entwicklungen Progressive Harmonic Imaging und jetzt auch Ultra Progressive Harmonic Imaging ermöglichen ein sehr dynamisches Spiel – ohne hörbare Sprünge – vom nuancierten Pianissimo bis hin zum kraftvollen Fortissimo.



Strong maximum polyphony specifications ensure complex passages can be played using the damper pedal without 'dropping' notes unexpectedly, while additional instrument sounds bring variety to one's performance.



Die hohe Polyphonie unterstreicht die Position Kawai's auf dem Digital Piano Markt. Pianisten können komplexe Musikstücke – mit schnellen Passagen und betätigen des Dämpferpedals – spielen, ohne dass immer wieder gespielte Noten ungewollt verstummen.



The convenient lesson feature allows aspiring pianists to learn the piano using a built-in collection of etudes from Czerny, Burgmüller and Beyer, or songs from the popular Alfred Basic, Adult and Premier course books.

Die leistungsstarke Lesson Funktion unterstützt den angehenden Pianisten beim Erlernen des Klavierspiels durch eine integrierte Sammlung – für den Klavierunterricht typischer Etüden – von Czerny, Beyer und Burgmüller.



Digital pianos equipped with a USB to Host connector allow MIDI data to be exchanged with a computer, while models featuring a USB to Device connector are also able to load and save data directly to USB memory.



Digitalpiano Modelle, die über einem USB to Host Anschluss verfügen, können MIDI Daten mit einem Computer austauschen, während Modelle mit einem USB to Device Anschluss zusätzlich Daten von einem USB-Speichermedium laden und darauf speichern können.



The Hybrid mark classifies instruments that combine traditional acoustic processes with modern digital technology in equal balance, and reaffirms Kawai's enduring commitment to producing the world's finest pianos.

Die Bezeichnung Hybrid klassifiziert die Kombination von traditionellen akustischen Instrumenten oder Komponenten, die gleichzeitig über eine digitale Klangerzeugung verfügen. Diese Kombination zeigt einmal mehr das dauerhafte Engagement Kawai's bei der Herstellung erstklassiger Pianos.

DIGITAL PIANO FINISHES

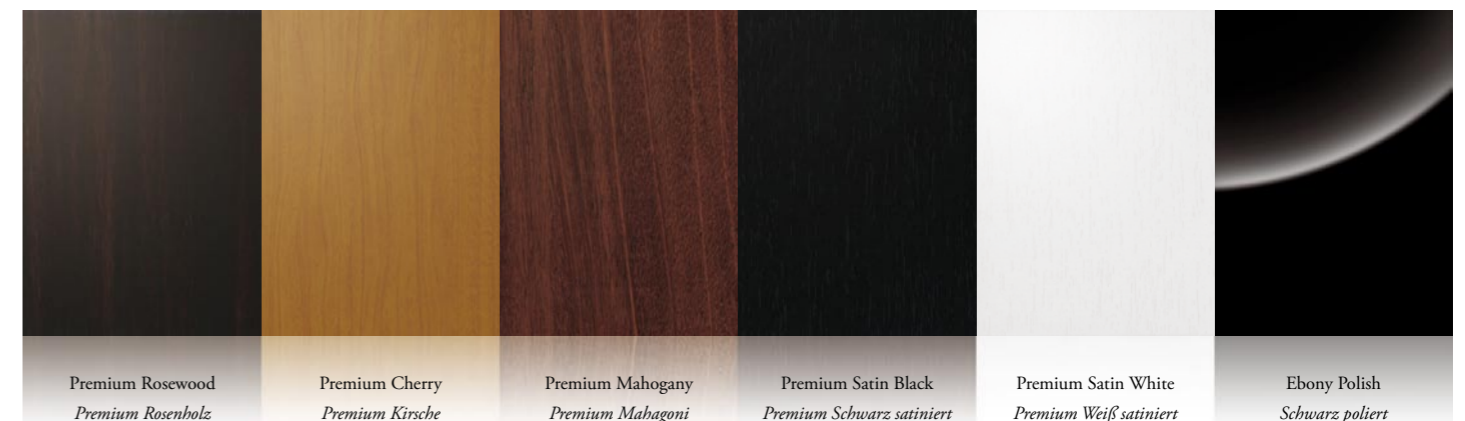

Availability of cabinet finishes may vary depending on market area. / Nicht in allen Verkaufsbereichen ist jede Farbvariante verfügbar.

KAWAI
THE FUTURE OF THE PIANO